

Wacker Neuson 1001

The Wacker Neuson 1 tonne site dumper is ideal for tight access applications and comes with high lift tipping capability.

KEY FEATURES

- Maximum payload 1,000kg
- Highlift tipping (1.56m dumping height)
- Hydrostatic twin-lock four-wheel drive
- 45% gradeability
- Folding ROPS
- 3.2m turning radius

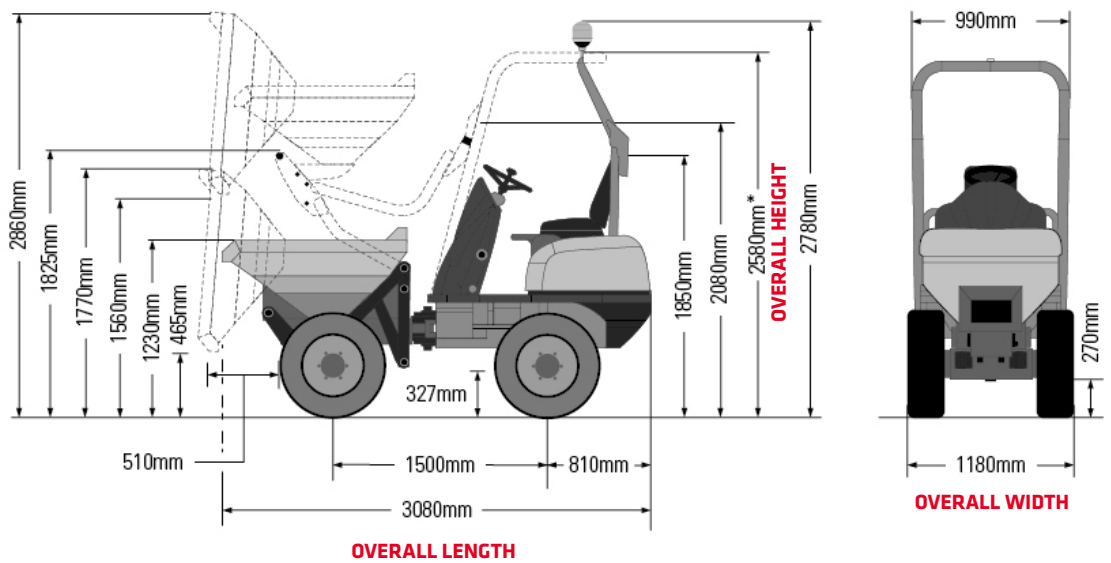

MAX SAFE CARRYING WEIGHT: 1,000KG | **LEVELLED CAPACITY:** 415L | **HEAPED CAPACITY:** 525L

*Finished height of ROPS