

Wacker Neuson RD27 - 120

The specially tapered design of the tandem-axle rollers allows for a clear view of your environment and job site. Furthermore, it ensures optimal compaction results with this simple construction technique.

KEY FEATURES

- Crab Steering
- Articulated pendulum joint
- Tandem-axle roller
- Fixed safe ROPS
- Optimal operator visibility

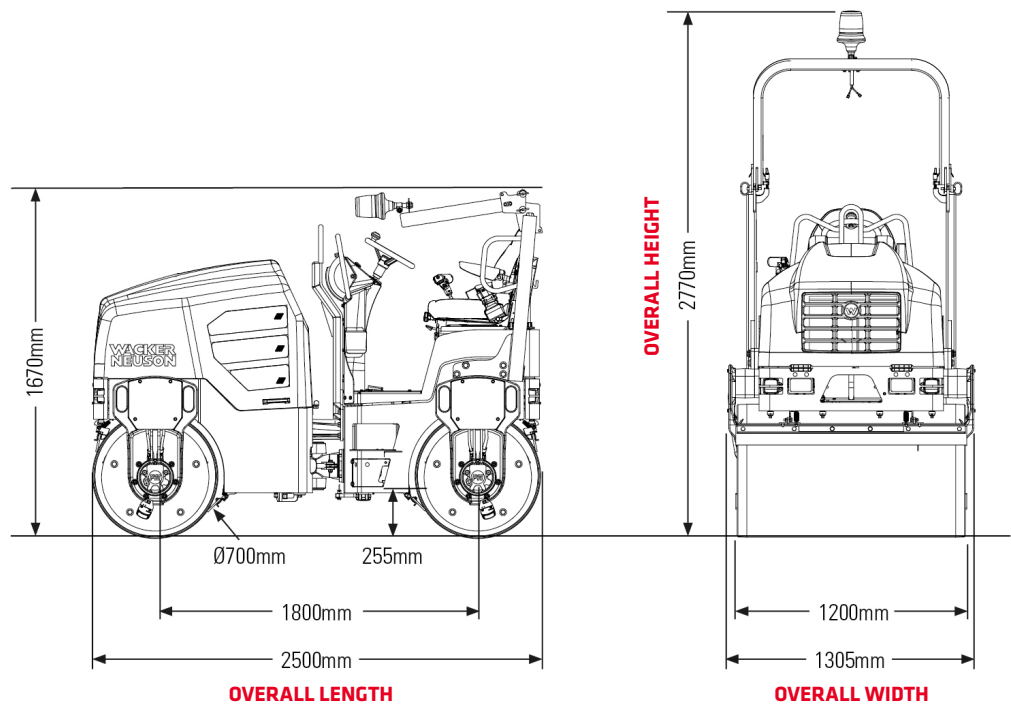

x - Approximate fuel consumption