

Wacker Neuson RD45-140

The Wacker Neuson roller (4T) exerts high centrifugal force and can provide brilliant compaction results. This versatile model comes with traditional dual vibrating drums with improved ergonomics.

KEY FEATURES

- First-class compaction performance
- Vibrate and oscillate in two levels
- Reduced vibration on operator platform
- Articulated pendulum joint
- Drum offset to compact near walls
- Optimal view of drum edges



6-7 ^{LT}/_{HR} x



4,345
KG



Tilt Tray



HINO HIRE

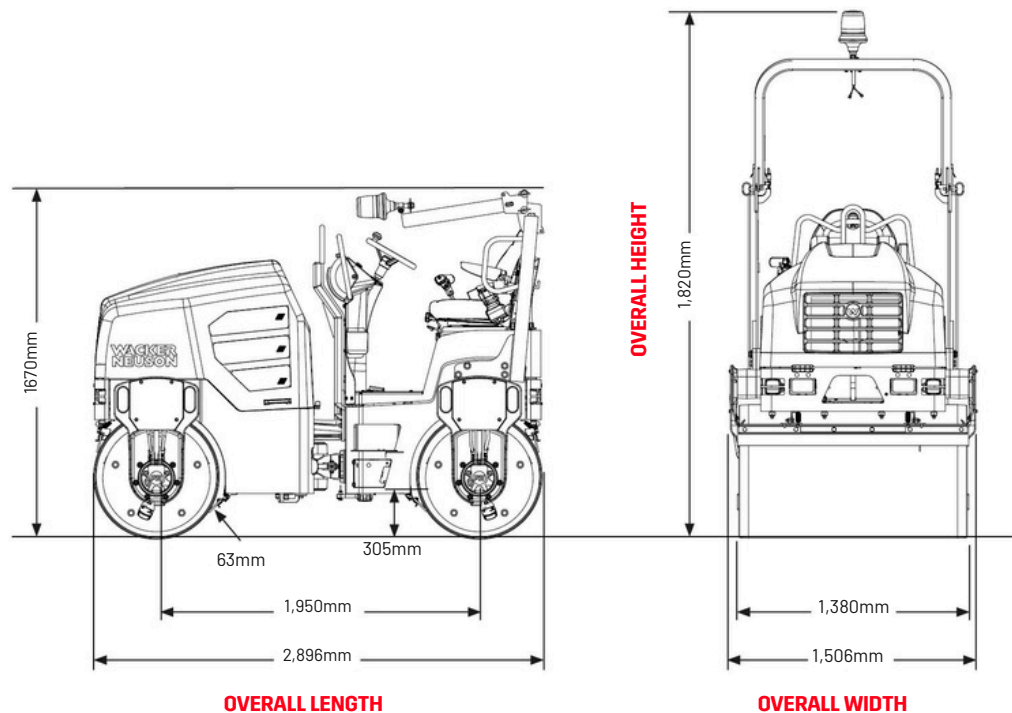

x - Approximate fuel consumption